

Installation and Operating Instructions

Description: **ROBINHOOD IRONING CENTRE SURFACE MOUNTING KIT**
Model Numbers: **ICSMK**
Code: **150273**

Pre-installation

Thank you for purchasing a quality Robinhood ironing surface mounting kit. This kit is designed to fit a surface mounted IC1300 Ironing Centre.

Important:

- Please read the entire instructions before installing the ironing centre/surface mounting kit.
- Please allow 100mm clear area on either side of ironing centre for surface mounting kit installation.
- (Alternatively install surface mounting kit to Ironing Centre before installing to the wall)
- Should you be fitting a door to the enclosure holding this product, please be mindful of the position of all door furniture (hinges, handles etc). Specifically ensure the board will operate without obstruction.
- Do not place EXCESSIVE WEIGHT (weight should not exceed 15kg) on the ironing board when opened, as it is designed to only accept normal ironing use only.
- The product is not intended for use by small children or infirm persons without supervision.

Contents of packaging:

- 2 x collar sides (A)
- 1 x collar top (B)
- 1 x collar bottom (C)
- 1 x instructions
- 1 x packet of fasteners

Typical equipment required:

- electric drill
- screwdriver
- tape measure
- spirit level

- 2 x edge covers(D), 8 x small screws size 6" x 1/4"(E), 6 x large screws size 8" x 3/4"(F), 1 x edge saddle (G)

Collar Kit Assembly

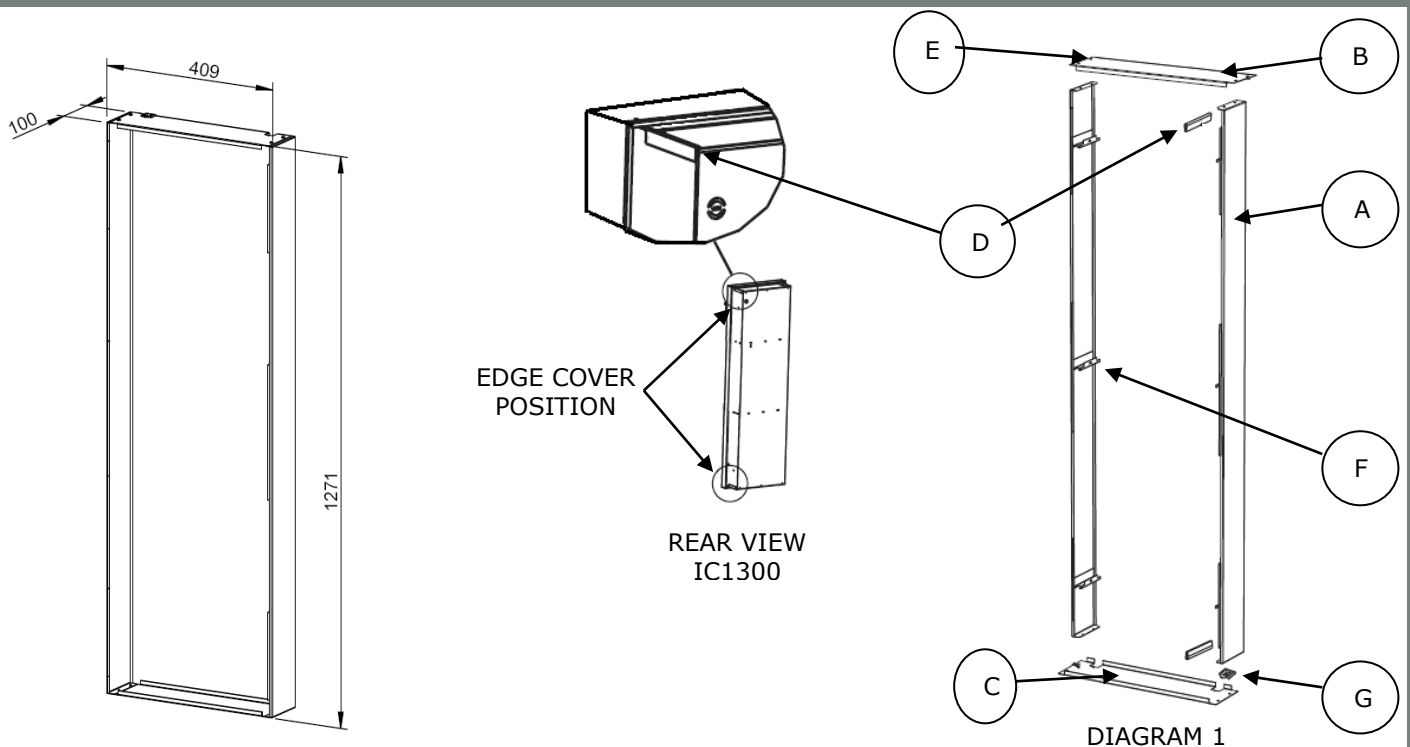

Surface Mounting Kit Assembly to IC1300 Ironing Centre

-  Note - this kit is interchangeable to allow the power cord to exit at either the top or bottom of the unit. Just swap part (B) with part (C) during installation and take note of power cord route. Follow the Ironing Centre installation instruction to mount the Ironing Centre to the wall.

Instructions for fitting the collar with power exiting at the bottom.

1. Clip the edge covers (D) into position (Diagram. 1).
2. Remove the wire way cover (for IC1300, IC300/200 models only) (Diagram. 3).
3. Run the power cord through the brackets of the collar side (A) (for IC1300, IC300/200 models only) (Diagram 2).
4. Position collar side (A) to ironing centre and swing into place (Diagram 3).
5. Screw collar side (A) in place from inside using three screws supplied (F).
6. Repeat for second side.
7. Place collar top (B) on top of unit and line up holes.
8. Screw collar top (B) in place using four screws supplied (E).
9. Slide edge saddle (G) into collar bottom (C) to protect the power cord (for IC1300, IC300/200 models only) (Diagram 4).
10. Pass the power cord through the edge saddle (for IC1300, IC300/200 models only).
11. Position collar bottom (C) in place on the bottom of the ironing centre and align holes.
12. Screw collar bottom (C) in place using four screws supplied (E).
13. Refit the wire way cover (for IC1300, IC300/200 models only).

RUN THE POWER CORD
THROUGH THE BRACKET

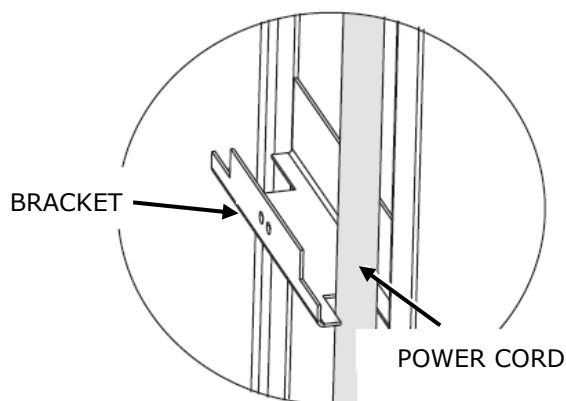

DIAGRAM 2

SWING CLOSED
COLLAR SIDE

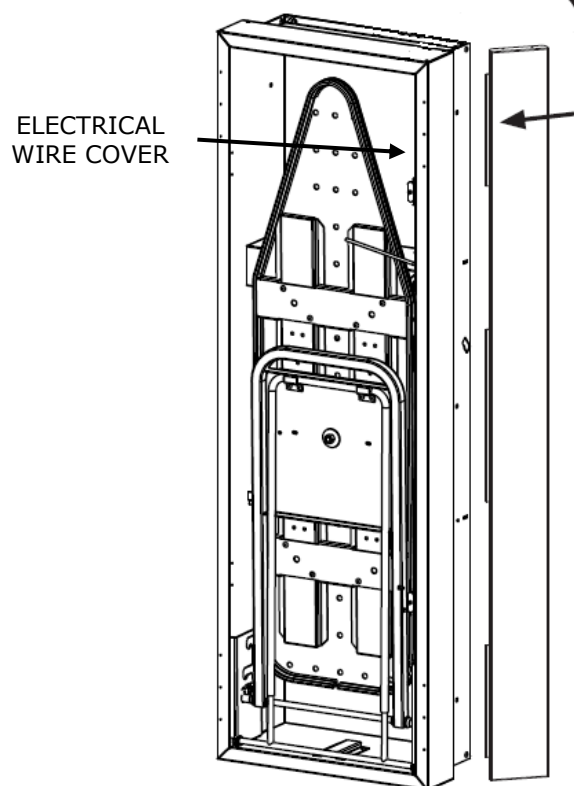

DIAGRAM 3

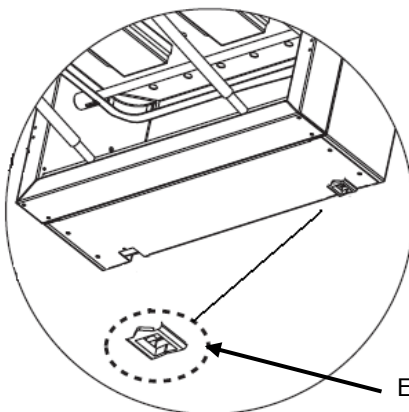

DIAGRAM 4